

SANIACCESS® 3

SANIACCESS® 3 is used to add a full bathroom, domestic or commercial, it takes waste from a toilet, shower, washbasin, and bidet.

A water pump, with integrated cutter

Removable panels on top of the unit, making it easy for servicing and maintenance.



TECHNICAL CHARACTERISTICS	
Discharge	22 - 40mm
Motor	400 Watts / 2.3A
Voltage	220-240 V / 50 Hz
Working Water Temp	35° C
Product Weight	7kg's
Overall Measurements	462 x 295 x 168 mm
Inlet Pipe Work	40mm
IP Rating	IP44
Maximum flow rate	96 L/min
Max discharge hight	5 m

WHY CHOOSE THIS PRODUCT

Quiet technology

Suitable for toilet, wash basin and shower

Ideal for adding a complete bathroom or En-Suit bathroom

Easy access to pressure chamber and cutter cage for accidental blockages

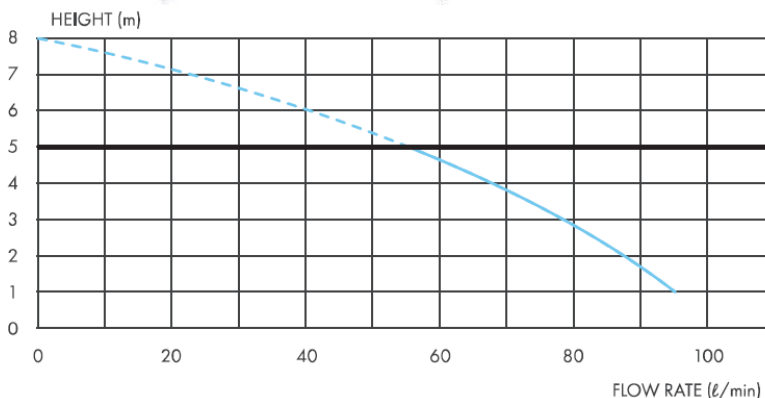
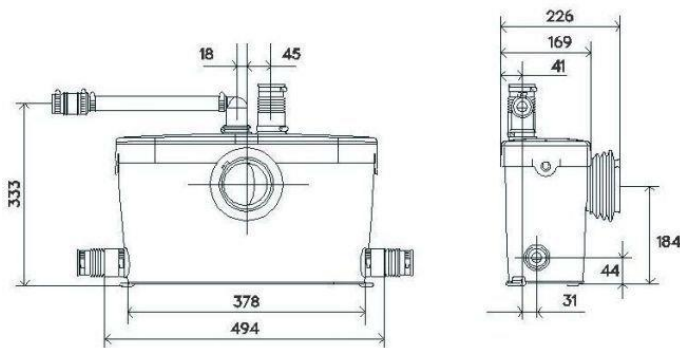

APPLICATION



TOILET



HAND BASIN



SHOWER

SANIACCESS® 3



A: Discharge

B: Inlets

C: Toilet connection

Built In Carbon Vent

Product Reference: ACCESS3

EASY ACCESS



Saniflo

SFA SOUTH AFRICA
Shaking up water

Made in France to the highest standards, needs to be installed by a licensed plumber.